

BERT FRANK

KERNEL TABLE LAMP

MAINTENANCE

- Lacquered brass and glass should be wiped with a soft duster.
- Coloured parts can be wiped with a damp cloth (unplug from mains first).

TECHNICAL

- 2 x G9 LED bulbs

www.bertfrank.co.uk
+44 (0)207 164 6482

BULB REPLACEMENT

- 1**
- Unplug the lamp from the mains.
 - Unscrew the 6 x screws on the underside of the shade.

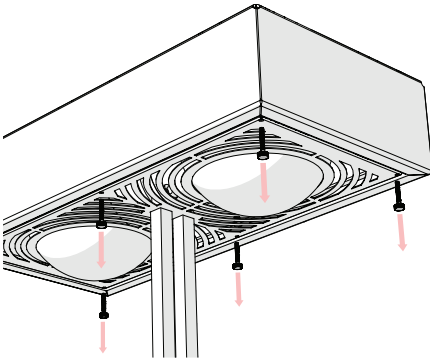

- 2**
- Unscrew the 2 x screw caps on the top of the shade.

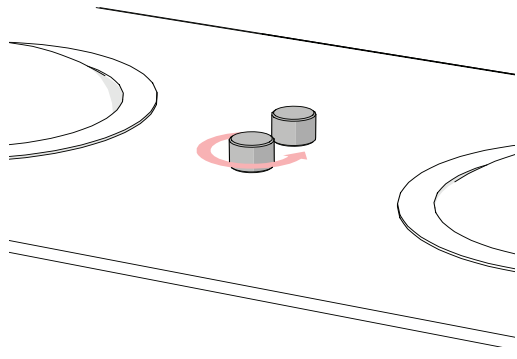

- 3**
- Remove the rectangular shade off the stem of the lamp exposing the glass globes.

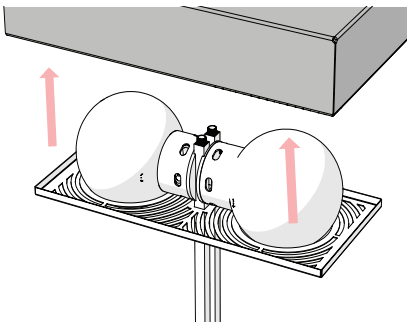

- 4**
- Holding the glass globe in one hand pull it away from the stem of the lamp until it is released from the spring clips.
 - Keep fingers away from the aluminium collar.

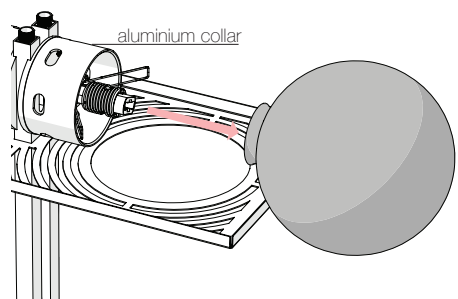

BULB REPLACEMENT CONTINUED...

- 5** - Replace G9 bulbs by pushing them into lamp holder.

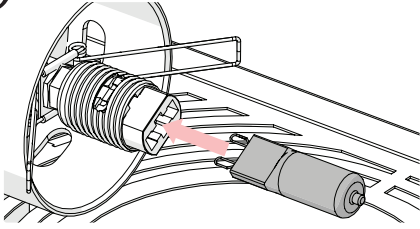

!! If lamp has been in use recently ensure you leave enough time for the old bulbs to cool down before removing them. !!

- 6** - Pinch the two ends of the spring clips together.
- Slide them back into the neck of the glass globe.
- The globe should fit back into the collar. **Be careful not to catch your fingers.**

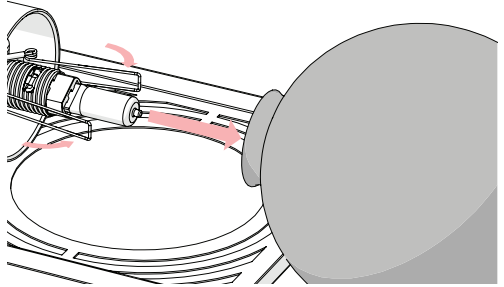

- 7** - Repeat the process with the other glass globe.
- Replace the rectangular shade back on stem and replace all the screws on the underside and top.

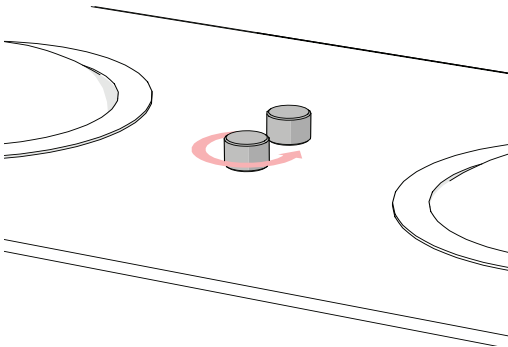

8

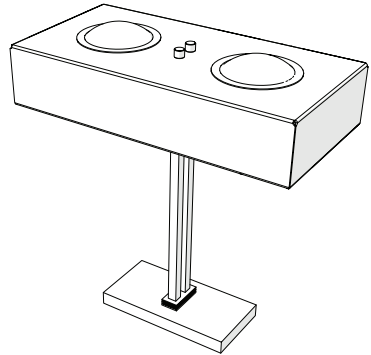

This product is only suitable for connection to the native power supply to which the unit was specifically manufactured. It is for indoor use only, and not suitable for a bathroom location.

If the Class II, double insulated symbol is on the lamp, it does not require an Earth, and Live or Neutral must not be connected to Earth. If there is no such symbol, then the lamp must be Earthed.

Never fit bulbs of a higher wattage than those specified on the label, as these may cause overheating and damage the fitting.

Under no circumstances must this table lamp be covered with any material as this could pose a safety hazard. It must be used on a stable, flat surface.

If the mains cable becomes damaged it must only be replaced by a technically competent, qualified person.

Allow 10 minutes to cool before replacing, adjusting or cleaning. Clean with a dry cloth only. Do not use liquid or abrasive cleaners on this product.

If you are in any doubt about your competence please consult a qualified electrician. If any modification is made it will invalidate the warranty and may render the product unsafe.